

Ecoboiler

SERVICE MANUAL



Marco Beverage Systems Ltd.

63d Heather Road,
Sandyford Industrial Estate,
Dublin 18,
Republic of Ireland

Ireland Tel: (01) 295 2674

Ireland Fax: (01) 295 3715

UK Tel: (0207) 274 4577

UK Fax: (0207) 978 8141

CONTENTS:

	PAGE
1. INTRODUCTION	3
2. SAFETY INSTRUCTIONS	4
3. BASIC INSTRUCTIONS	5
3.1. Installation Details	5
3.2. Operation	5
3.3. Temperature Calibration	6
3.4. Time/Volume Dispense Calibration	7
3.5. Troubleshooting	7
3.6. Maintenance	8
3.7. Cleaning	8
3.8. Limescale	8
3.9. Cautions and Safety Tips	8
4. TECHNICAL DATA	9
4.1. General Description	9
4.2. External Arrangement	9
4.3. Access to internal components	10
4.4. Internal Arrangement	12
4.5. PCBs	12
4.5.1. PCB Layout	12
4.5.2. PCB Ecoboiler Control – 1600345	13
4.5.3. PCB Ecoboiler Display 5L – 1600348	14
4.5.4. PCB Ecoboiler Display 10L – 1600349	14
4.6. Troubleshooting – Diagnostic guide	15
4.7. Tank Components	16
4.8. Descaling procedure	17
4.9. Wiring Diagram 1000660 Ecoboiler T5	18
4.10. Wiring Diagram 1000661 Ecoboiler T10	19
4.11. Wiring Diagram 1000665 Ecoboiler PB5	20
4.12. Wiring Diagram 1000666 Ecoboiler PB10	21
4.13. Spare Parts List	22

1. INTRODUCTION:

The information provided in this manual is intended to assist in the installation and maintenance of the Marco Ecoboiler Water boiler. Please read the instructions carefully to prevent accidents and ensure an efficient installation.

This manual is not a substitute for any safety instructions or technical data affixed to the machine or its packaging. All information in this manual is current at the time of publication and is subject to change without notice.

Only technicians or service providers authorised by Marco should carry out installation and maintenance of these machines.

Marco accepts no responsibility for any damage or injury caused by incorrect or unreasonable installation and operation.

2. SAFETY INSTRUCTIONS:

- Read all instructions.
- To protect against electric shock do not immerse mains cord in water or other liquid.
- To prevent chafing of the cable, do not let the mains cord hang over the edge of a table or counter ; or touch hot surfaces.
- Do not operate any appliance with a damaged cord, plugs, or after the appliance malfunctions or has been damaged in any manner.
- Switch off at the mains (unplug or disconnect from outlet) and turn off the water supply when not in use and before cleaning. Allow to cool before removing components.
- The use of spares and accessories not recommended by Marco may cause damage and/or injuries.
- Do not use outdoors. Do not place on or near a hot gas or electric burner.
- Do not use the appliance for anything other than its intended use.
- Save these instructions.

3. BASIC INSTRUCTIONS:

3.1. INSTALLATION DETAILS:

Electrical installation:

- ECO Boiler PB5, PB10, T5, T10 (2.8kW) - A moulded 13A plug is factory fitted. A suitable 13A outlet is all that is required.

Plumbing installation procedure:

Note: Marco recommend that this machine be positioned on a counter with a drainage facility. Marco cannot be held responsible for any flood damages.

- Mains water pressure required (limits): 5-50psi (35-345kPa)
- Fit a stop Valve on a cold water line and attach a 3/4" BSP male fitting, (e.g. 3/4" x 1/2" 311 or washing machine type stop valve).
- Connect straight tailpiece of the inlet hose to the stop valve fitting. Make sure that the pre-attached sealing washer is fitted.
- Turn on the water to flush any impurities, dust etc from the inlet hose and water pipe. Allow several gallons through.
- Connect right-angled tailpiece of the hose to the inlet valve of the boiler (again 3/4" BSP). Make sure the sealing washer is fitted here also.
- Turn on water and check for leaks.

3.2. OPERATION:

- Check that all installation procedures have been carried out.
- Ensure water valve is on.
- Plug boiler into 13A socket and press power button on the front of the machine marked 'Power'. Refer to Figure 1.

NOTE: On a 5L machine the 'Power' button light also acts as the "Ready/Status" indicator.

- The "power on" light will glow green and the machine will fill to a safe level, above the elements, before heating.
- The "Ready/Status" light will cycle two red flashes while the machine is filling to the safe level.
- After this amount of water has heated to about 96°C the boiler will draw more water in until the temperature drops by 1 or 2 degrees. The boiler will then heat again. This heat fill cycle continues until the boiler is full.
- On a 5L machine, whilst the machine is above the safe level and filling, the "Ready/Status" light will glow orange.
- On a 10L machine, whilst the machine is above the safe level and filling, the "Ready/Status" light will remain blank.
- The "Ready/Status" light will glow green when the machine is both full and up to normal operating temperature.
- The boiler is now ready for use.

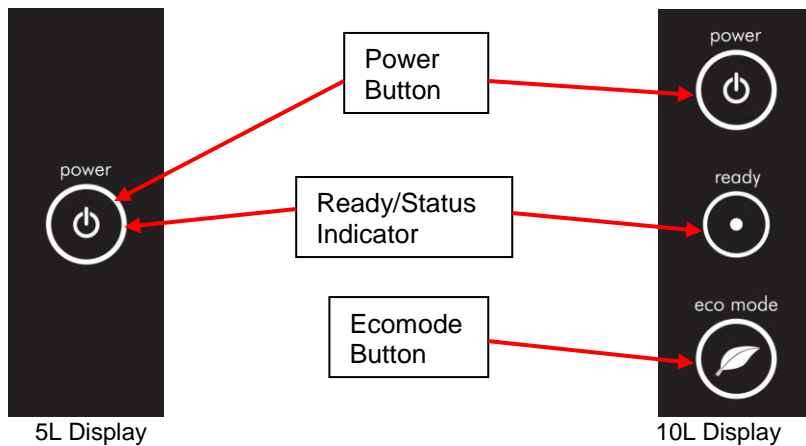

Figure 1: Machine User Interface

NOTE:

Because the boiler is electronically controlled no priming is necessary. The element cannot switch on until a safe level of water is reached.

3.3. TEMPERATURE CALIBRATION

The Ecoboiler control PCB (1600345) has the ability to have the desired set-point temperature at whatever setting is required. During manufacture of the PCB it is set to the default temperature of around 95°C.

If the temperature setting needs to be modified on-site please follow the steps below:

1. To Enter Calibration mode:
 - a. Turn the machine off at the mains power supply.
 - b. Then, whilst depressing the tactile switch on the PCB, turn the mains power back on.
 - c. All available LED's on the front panel will now blink continuously.
 - d. The machine is now in Calibration mode.
2. In Calibration Mode the machine will heat continuously until the tactile switch on the PCB is pressed for a second time (NB: The tactile switch should be pressed for at least 1 second)
3. Using a thermometer to measure the temperature at the thermistor pocket, the machine should be allowed to reach the desired set-temperature. (NB: It may be necessary to let the unit cool down if the desired set point is lower than the units current temperature)
4. Following a correct calibration procedure the tank temperature should be maintained within 3°C of the desired set-point temperature.

In the event of an incorrect calibration process the steps below should be followed:

5. If the tactile switch is pressed too early and the temperature is set lower than desired, the tester should simply repeat calibration.
6. If the tactile switch is pressed too late and the set temperature is too high, the tester will need to wait for the temperature in the tank to cool, or add cool water, and then repeat calibration.

3.4. TIME/VOLUME DISPENSE CALIBRATION

1. Open the front - bottom panel.
2. Make sure that the machine is powered, filled and heated (ready lamp green).
3. Press calibration tactile button on the PCB for a second until status lamp starts blinking red-green.
4. Set new dispense time by pressing dispense button to obtain the required output volume of water. Button may be pressed several times – all times / volumes will be added together.
5. To confirm and save new value press calibration button on the PCB for a second until the status lamp stops blinking.
6. Setting dispense time / volume to zero (omit step 4) will make the machine work as “push & hold” (water dispensed as long as the button is pressed).

3.5. TROUBLESHOOTING

The Ready/Status light signals various errors or problems.

A cycle of red flashes indicates an error. The number of flashes in a cycle corresponds to the symptom in the table below:

Status/Diagnostic light guide:

No of flashes	Symptom	Action required
2	Water level below elements. Normal when machine first fills.	Check water pressure , if this is OK then call service agent.
3	Temperature sensor failure (o/c)	Call service agent
4	Water not heating	Call service agent
5	Temperature sensor failure (s/c)	Call service agent
6	Machine not filling	Check water pressure. If OK – switch machine off and on again. If problem reoccurs - call service agent.

Note: Some of the error sequences will be displayed if there is low water pressure. Please check that there is water pressure and that the water stop-valve is open before calling your service agent.

For a more detailed description of error indicators and corrective actions see section 4.7 of this manual.

3.6. MAINTENANCE:

Marco machines have been designed to give many years of trouble free service. Marco Beverage Systems manufacture and test to ISO9002:2000 standard. The only regular maintenance required is occasional de-scaling.

Descaling Procedure:

- Isolate machine from power supply.
- Isolate machine from water supply.
- ALLOW TO COOL COMPLETELY!
- Drain water from machine.
- Remove all lids.
- Remove as much scale as possible by hand, paying particular attention to level probes (White plastic with steel tab). Be very careful not to damage any attachments.
- Use ScaleKleen, Marco part No. 8000270 or similar. Follow instructions carefully.
- Thoroughly clean and flush the machine before re-use.
- Follow installation and first time operation instructions

3.7. CLEANING:

The exterior of these machines may be cleaned with a damp cloth and a light detergent. Do not use abrasive cloths or creams, as this will spoil the finish of the machine. Do not use a water jet or spray. Beware of accidentally operating the draw off tap or push button when cleaning the front of the machine.

3.8. LIMESCALE:

In common with all water boiler manufacturers, service calls resulting from limescale are not covered by warranty. Fitting a scale reducer is recommended, especially in hard water areas. This can reduce the build-up of scale but may not stop it altogether. The frequency that descaling is required depends on the local water supply; hard water areas need more attention. A scale reducer can reduce the build up of scaling, but may not stop it altogether. Descaling of the machine should ideally be carried out by qualified service personnel.

3.9. CAUTIONS AND SAFETY TIPS:

- This appliance must be earthed. If the moulded plug supplied is not used then ensure that the green/yellow cable is connected to a suitable earth.
- Risk of flooding. The hose supplied with this unit is non-toxic food quality tested to 190psi. However, a hose is not a permanent connection. It is, therefore, advisable to switch off boiler and close the stopcock valve when boiler is not in use, e.g. overnight, weekends etc.
- Risk of scalding. Beware of accidentally operating the water drawoff tap especially when cleaning the front of the boiler.
- The utmost care has been taken in the manufacture and testing of this unit. Failure to install, maintain and / or operate this boiler according to the manufacturer's instructions may result in conditions that can cause injury or damage to property. If in any doubt about the serviceability of the boiler always contact the manufacturer or your own supplier for advice.

4. Technical Data:

4.1. GENERAL DESCRIPTION:

ECO Boiler PB5, PB10, T5, T10.

		PB5	PB10	T5	T10
Dimensions	Height (mm)	465	590	465	590
	Width (mm)	210	210	210	210
	Depth – counter footprint (mm)	360	360	360	360
	Depth – to front of Tap (mm)	-	-	470	470
	Depth incl. Drip Tray (mm)	460	460	510	510
Performance	Immediate Draw-Off (litres)	5	10	5	10
	Max. Hourly Output (litres/hour)	33	38	33	38
Electrical	Connection	2.8kW, 230V, c/w 1.5m flex and moulded plug - fused (BS1363).			
Plumbing	Fittings Pressure	0.75" BSP Food grade inlet hose supplied 5-50 psi (35-345 kPa)			

4.2. EXTERNAL ARRANGEMENT:

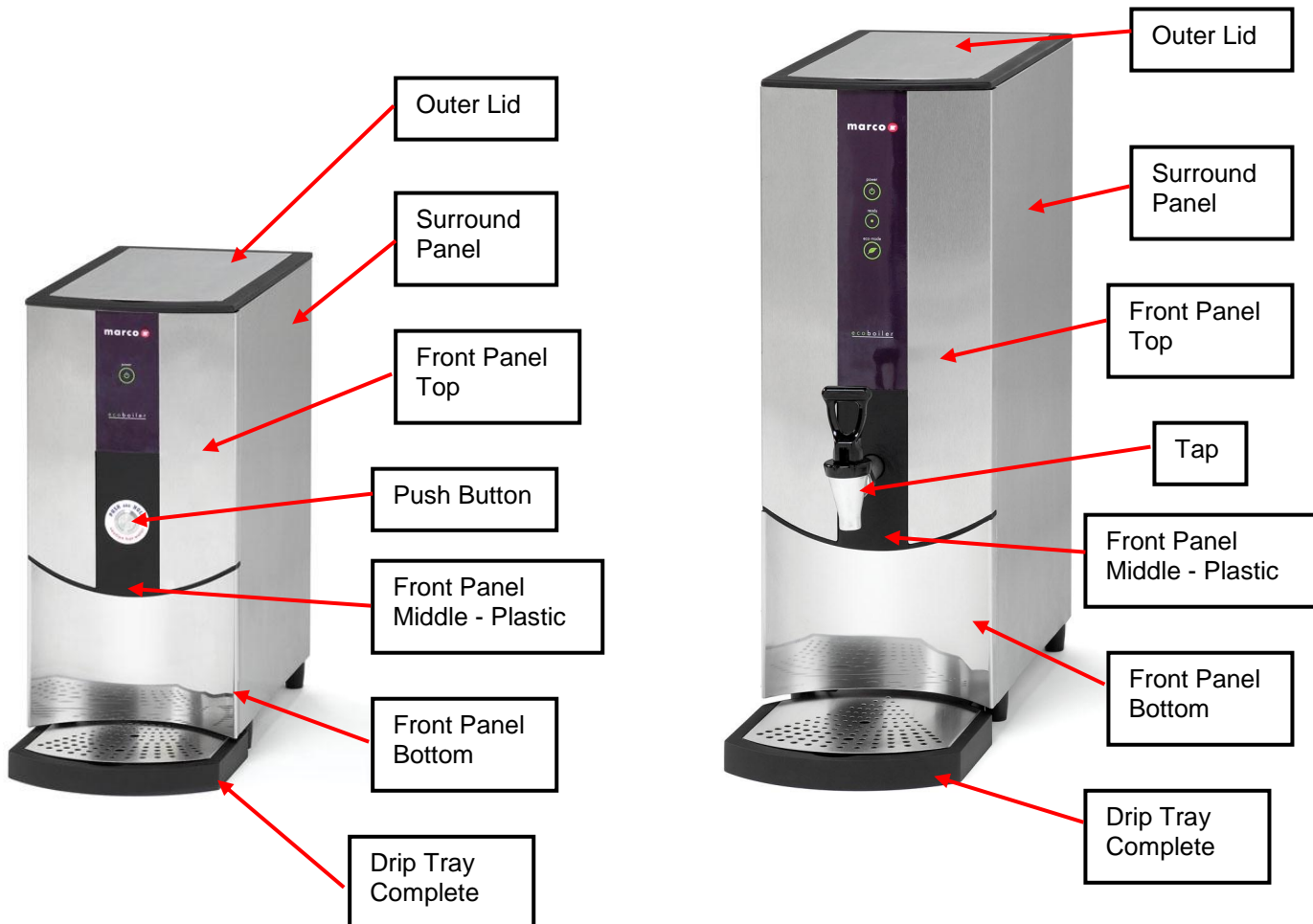

4.3. ACCESS TO INTERNAL COMPONENTS:

To access the tank:

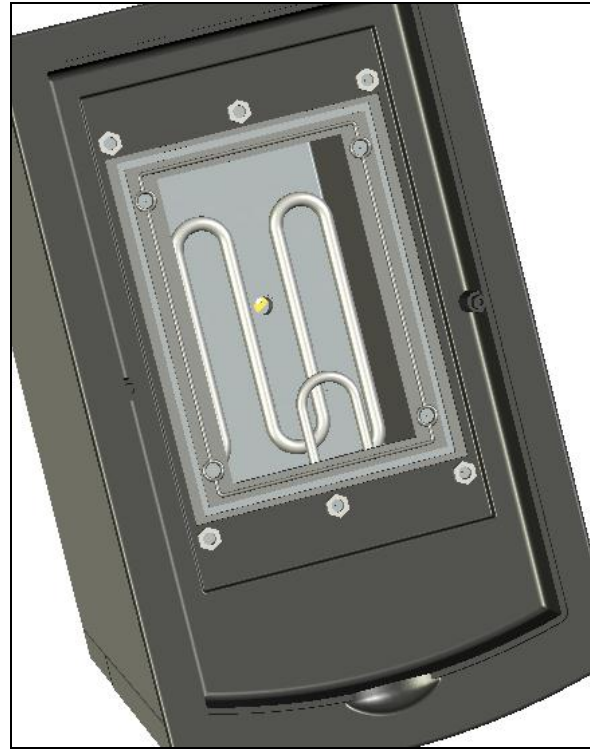
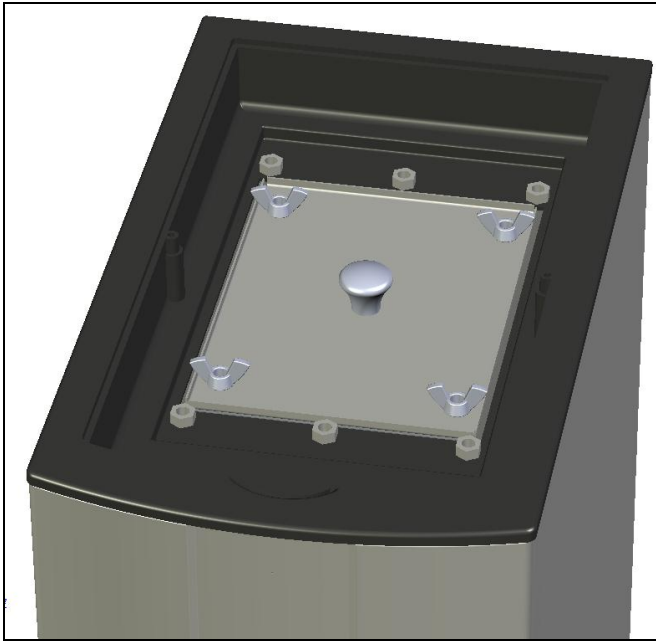

Allow to cool. Remove the outer lid.

Ensure that the tank is cool, before removing inner lid. To remove inner lid, undo 4 butterfly nuts

The tank is now accessible for cleaning.

To access the internal components:



Ball Stud/
Spring Clip
locations

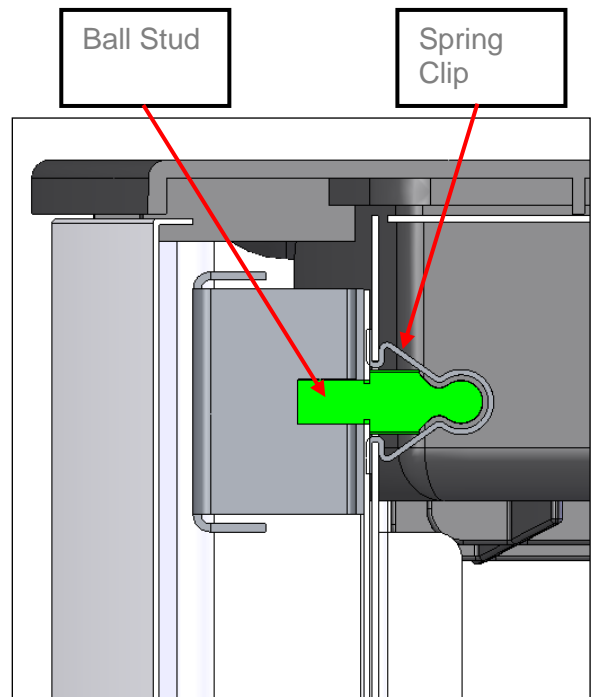

Ball Stud

Spring
Clip

- Disconnect the machine from the electrical supply.
- Allow to cool sufficiently.
- The metal Front Fascia Top and Bottom panels are fixed to the surround with ball studs that lock into spring clips mounted in the surround panel – refer to picture above.
- To separate the ball studs from the spring clips insert a flat headed screwdriver at the locations indicated on the picture and lever apart the front panels from the surround.
- To remove the Front Fascia Top panel, after seperating the ball stud from the spring clip, rotate the top edge of the panel forward and pull the panel in an upwards motion.
- Place the panel to the side of the machine
- To remove the Front Fascia Bottom, after seperating the ball stud from the spring clip, rotate the bottom edge of panel forwards and pull in a downward motion. This panel is now free to be placed out of the way.



- This allows access to most of the internal components and the machine does not need to be drained for most maintenance or service operations.
- If further access is required, the plastic Front Fascia Middle panel should be removed by unscrewing the four cross recessed pan headed screws.
- On Tap versions, the Tap assembly will need to be removed before the plastic Front Fascia Middle can be removed.
- The Tank can be drained by removing the plug from the end of the drain hose, and draining into an external drain or a large enough container.

Inlet Solenoid Access:

- To access the inlet solenoid, the PCB and PCB bracket need to be removed.
- Unscrew the two crss-recessed pan headed screws holding the bracket in place.

4.4. INTERNAL ARRANGEMENT:

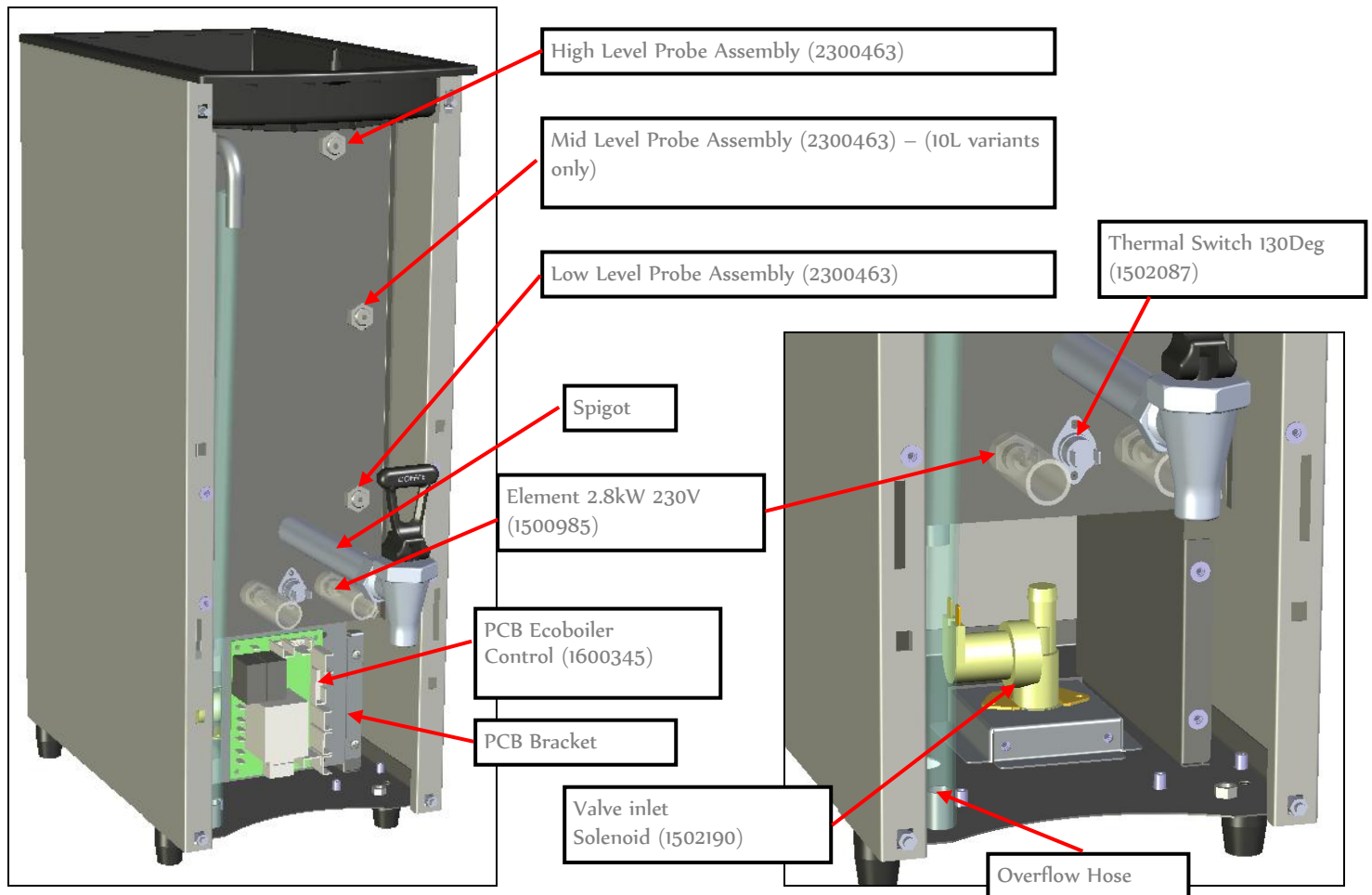

4.5. PCBs:

4.5.1. PCB Layout:

Internal PCB Layout:

PCB EcoBoiler Control (1600345):

- Controls the heater switching
- Controls the water inlet switching
- Controls tank temperature/temperature adjustment

PCB EcoBoiler Display 5L (1600348) consists of:

- Power On/Off button
- Power On LED
- Status/Ready LED

PCB EcoBoiler Display 10L (1600349) consists of:

- Power On/Off button
- Power On LED
- Status/Ready LED
- ECO Mode On/Off Button
- ECO Mode On LED

4.5.2. PCB Eco boiler Control:

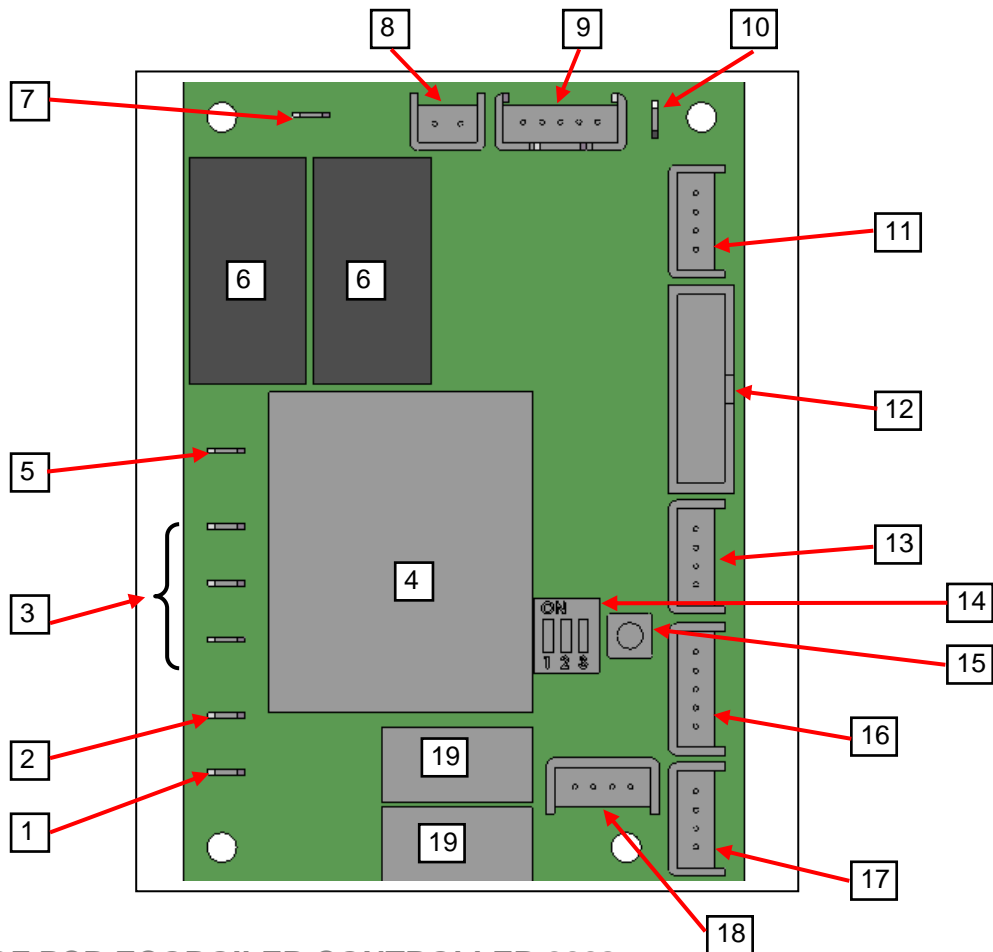

COMPONENTS OF PCB ECOBOILER CONTROLLER 2008:

1. Dispense Solenoid Tab
2. Inlet Solenoid Tab
3. Neutral Tabs
4. Transformer
5. Mains Live In Tab
6. Relays - Heater
 - Switch the element
7. Heater Tab
8. On/Off 2-way Connector
 - Short circuited on this Eco boiler machines – power switch controlled through the display PCB
9. LED 5-way Connector
10. Earth Tab
11. Daughter PCB Connector (low voltage)
 - Connects to Daughter PCBs – allows switching of more than one element
12. External Connector
13. Thermistor Connector
14. Dip Switch – 3 way
 - Allows selection of software for specific machine
15. Tactile Switch
 - For use during calibration procedure (refer to Calibration in Sec 3.3)
16. Water Level – 5-way connector (low voltage)
 - Connects to Low level and High level probes. Also connects push button on PB variants.
17. Button Connector – 4-way
18. Data I/O Connector – 4-way
19. Relays – Inlet Solenoid

4.5.3. PCB Display Ecoboiler 5L (1600348)

1. Power On LED's
 - shows that machine is switched on
2. Status LED's
 - displays Error signals via a flashing RED LED
3. Power On/Off switch
4. 5 way connector – to PCB Ecoboiler LED connector
5. 4 way connector – to PCB Ecoboiler BUTTONS connector

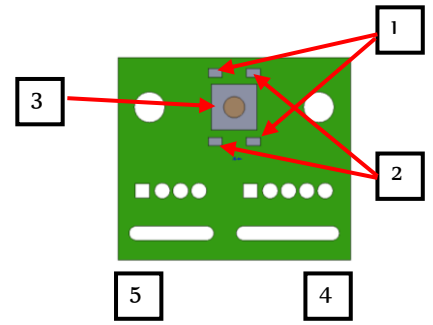

4.5.4. PCB Display Ecoboiler 10L (1600349)

1. Power On LED's
 - shows that machine is switched on
2. Power On/Off switch
3. Status LED's
 - displays Error signals via a flashing RED LED
4. Eco Mode On LED's
5. Eco Mode On/Of Switch
6. 5 way connector – to PCB Ecoboiler LED connector
7. 4 way connector – to PCB Ecoboiler BUTTONS connector

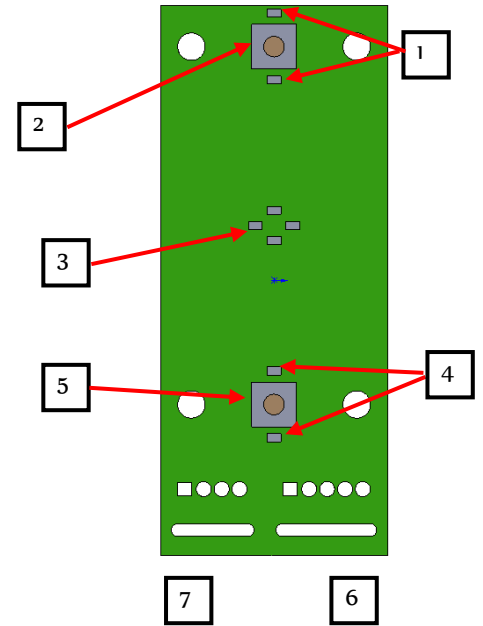

2 FLASH CYCLE – BELOW LOW LEVEL

Display pattern:

- 2 flashes then a short pause - repeated.

Electronic check and action:

- This indicates that the low level circuit is open i.e. the probe is not in contact with the water.
- The element is switched OFF at this stage and the inlet is left ON. (note that if this is a low probe wiring fault, the water will stop at the high level probe regardless of the status of the low level).
- This is a recoverable error i.e. the machine does not need to be reset when the problem is solved. (e.g. if a closed mains water stop valve is the problem, opening the valve will allow water into the machine and normal function will resume when the low level probe is reached)

Probable causes:

1. The water level is below the low level probe, which is normal when the machine fills for the first time. (Can be flashing for up to 2 min at start up)
2. The low level probe wire is disconnected, or there is another wiring fault (eg. a bad earth (return) connection between the PCB and the Tank)

Action required:

1. Check that the water pressure is OK and ensure that the stop valve is open.
2. Check that the inlet solenoid is working.
3. If the water level is above the level of the low probe, check the probe circuit wiring

3 FLASH CYCLE – THERMISTOR OPEN CIRCUIT

Display pattern:

- 3 flashes then a short pause - repeated.

Electronic check:

- This indicates that the Thermistor is measuring such a large resistance that it assumes the thermistor circuit is open.
- The element and inlet valve are turned OFF when this error is detected
- This is a recoverable error. When the correct range of resistance is measured, normal operation resumes

Probable causes:

1. The thermistor probe is unplugged from the 4way connector on the PCB or the thermistor has failed open circuit.

Action required:

1. Check that the thermistor is plugged in to the PCB correctly. If it is, replace the thermistor.

4 FLASH CYCLE – NOT HEATING

Display pattern:

- 4 flashes then a short pause - repeated.

Electronic check:

- This checks that the temperature is increasing when the heater is on.
- Measures the rate that the temperature increases in a specified time. This error is only displayed after 20 mins of the heater being on continuously. When the error is detected, the element and inlet valve are turned off.
- This is a non recoverable error. The machine needs to be reset when this problem is solved.

Probable causes:

1. The elements have failed
2. Wiring fault

4.6. TROUBLESHOOTING – DIAGNOSTIC GUIDE cont:

Action required:

1. Check that the resistance on the elements. If there is a reasonable resistance (15-25Ω) on the element it probably has not failed, so the wiring might be at fault.

5 FLASH CYCLE – THERMISTOR SHORT CIRCUIT

Display pattern:

- 5 flashes then a short pause - repeated.

Electronic check:

- This indicates that the Thermistor is measuring zero resistance. It assumes the thermistor has failed short circuit.
- The element and inlet valve are turned OFF when this error is detected
- This is a recoverable error. When the correct range of resistance is measured, normal operation resumes.

Probable causes:

2. The thermistor has failed.

Action required:

2. Replace the thermistor.

6 FLASH CYCLE – NOT FILLING

Display pattern:

- 6 flashes then a short pause - repeated.

Electronic check:

- This checks that the water in the tank cools when the inlet solenoid valve is switched on.
- This is a non-recoverable error. This checks that the water in the tank is cooled by when the inlet solenoid valve is opened. If the water pressure is within the specifications (5-50psi), the inlet solenoid should not be on for more than a few seconds. If this water temperature has not decreased by the required amount (1 degree per minute), the inlet solenoid is switched off and the 6 flash cycle is displayed.

Probable causes:

1. Mains water pressure problem or the mains water stop valve is closed.
2. Inlet solenoid valve failure.

Action required:

1. Check the mains water supply. (Note: Temporary loss of water pressure can occur in certain sites – particularly when various machines are plumbed to the same mains water supply.) If the water supply is ok, reset the machine (switch the machine Off and On again). This will reset the error and if the water supply is ok, the machine will return to normal operation.

NOTE: If the water supply is the problem, ensure that this is rectified or this error will re-occur.

2. If there is no problem with the mains water supply, check that the inlet solenoid valve is working.

4.7. Tank Components

The tank internals are detailed below. Care should be taken when cleaning inside the tank. The level probes provide much of the control inputs into the PCB and are critical to the operation of the machine. The wiring to these should be checked regularly and the probes themselves should be cleaned whenever the machine is serviced.

There are 3 level probes on the 10L Ecoboiler versions and 2 level probes on the 5L versions.

The Ecoboiler T10 tank is shown below – only the low level probe is visible in the picture.

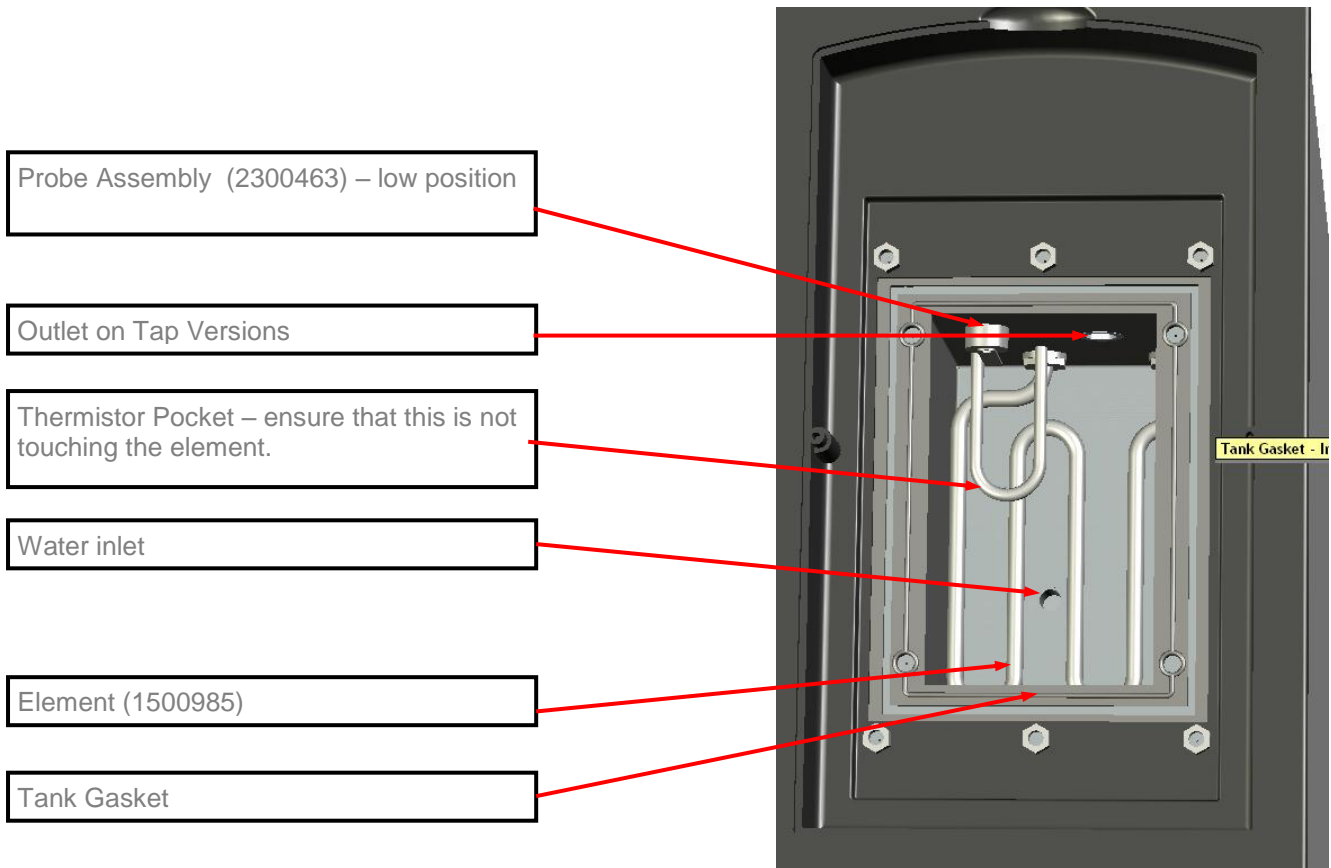

4.8. Descaling Procedure

To descale the machine thoroughly:

- Unplug the machine.
- Disconnect from the water supply.
- Drain as much water from the tank as possible.
- Remove the lids and allow the machine to cool completely.
- Drain all the water from the machine.
- Attempt to remove as much scale as possible by hand.
- Reconnect machine and start up once again.
- Add a descale solution (follow instructions as given). Flush the machine thoroughly before use

4.9. Wiring Diagram 1000660 Ecoboiler T5

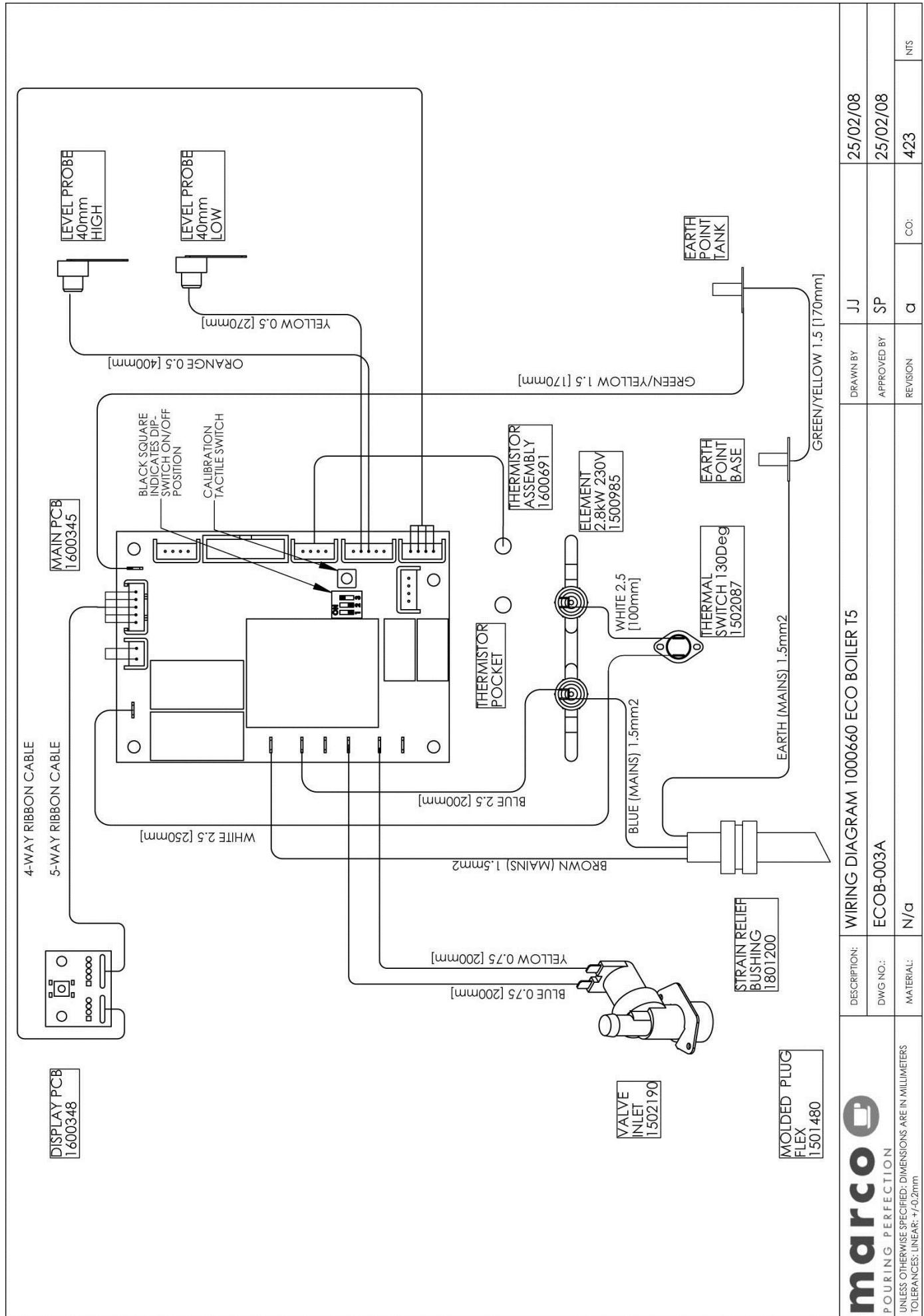

<p>POURING PERFECTION UNLESS OTHERWISE SPECIFIED: DIMENSIONS ARE IN MILLIMETERS TOLERANCES: LINEAR: +/0.2mm</p>	DESCRIPTION:	WIRING DIAGRAM 1000660 ECO BOILER T5	
	DWG NO.:	ECO-B-003A	
	MATERIAL:	N/a	
	DRAWN BY:	JJ	25/02/08
	APPROVED BY:	SP	25/02/08
	REVISION	α	CO: 423
			NTS

4.10. Wiring Diagrams 1000661 Eco boiler T10

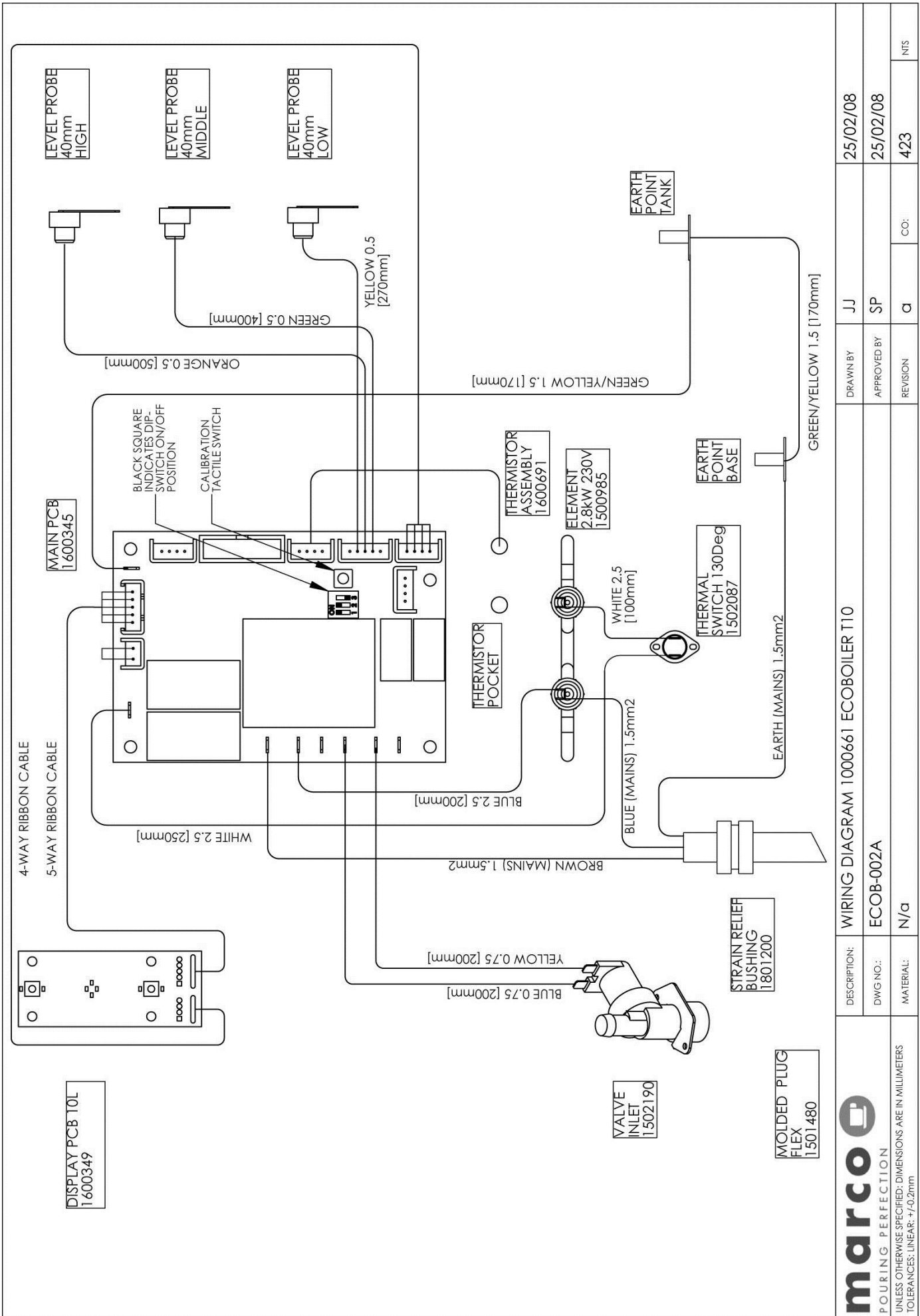

<p>POURING PERFECTION UNLESS OTHERWISE SPECIFIED: DIMENSIONS ARE IN MILLIMETERS TOLERANCES: LINEAR: +/0.2mm</p>	DESCRIPTION:	WIRING DIAGRAM 1000661 ECOBOILER T10		
	DWG NO.:	ECO-002A		
	MATERIAL:	N/a		
	DRAWN BY:	JJ	25/02/08	
	APPROVED BY:	SP	25/02/08	
	REVISION	α	CO:	423
				NTS

4.II. Wiring Diagram 1000665 EcoBoiler PB5

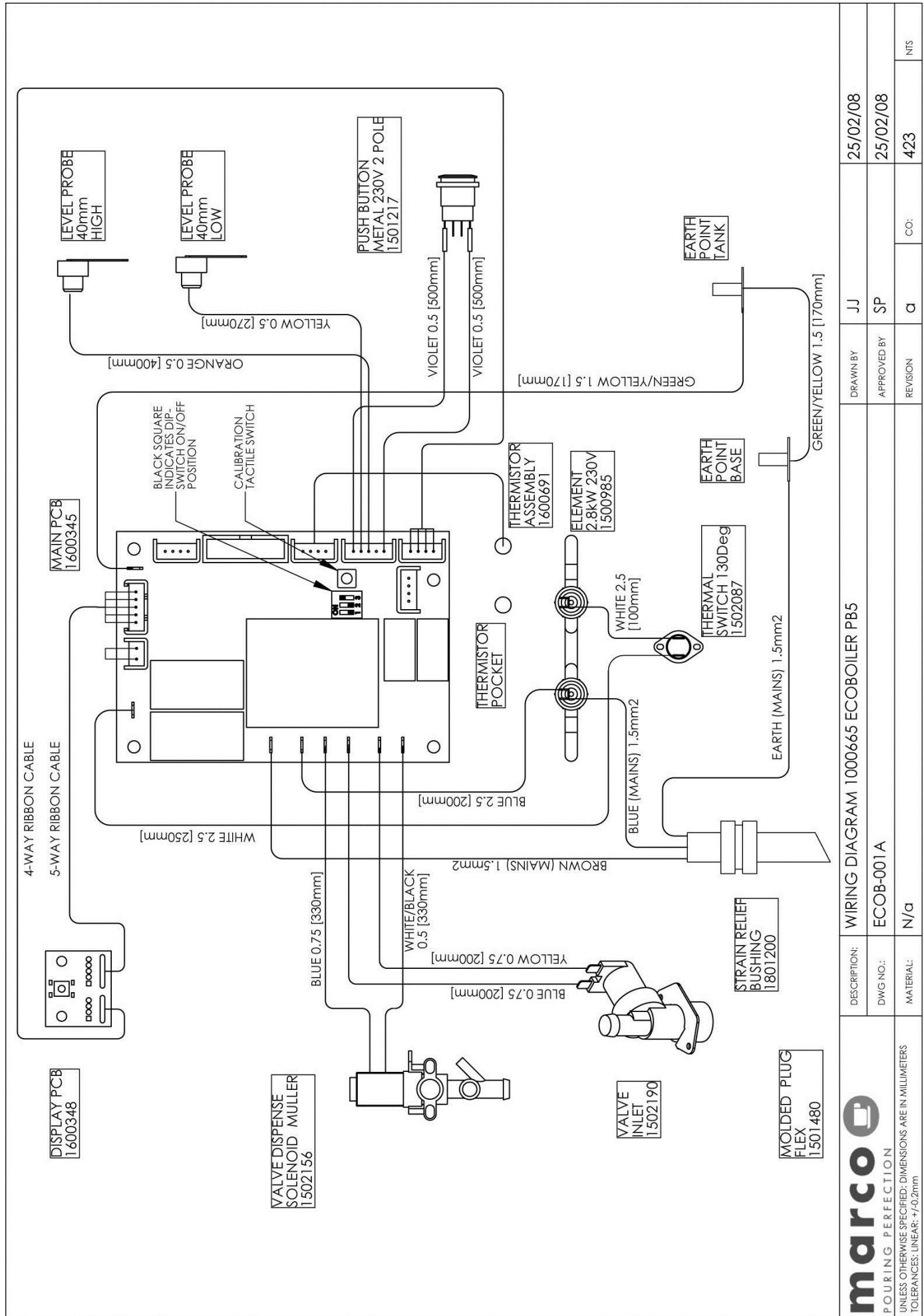

<p>marco POURING PERFECTION UNLESS OTHERWISE SPECIFIED: DIMENSIONS ARE IN MILLIMETERS TOLERANCES: LINEAR: +/0.2mm</p>	DESCRIPTION:	WIRING DIAGRAM 1000665 ECOBOILER PB5	
	DWG NO.:	ECO-001A	
	MATERIAL:	N/a	
	DRAWN BY:	JJ	25/02/08
	APPROVED BY:	SP	25/02/08
	REVISION	α	CO: 423
			NTS

4.12. Wiring Diagram 1000666 Eco boiler PB10

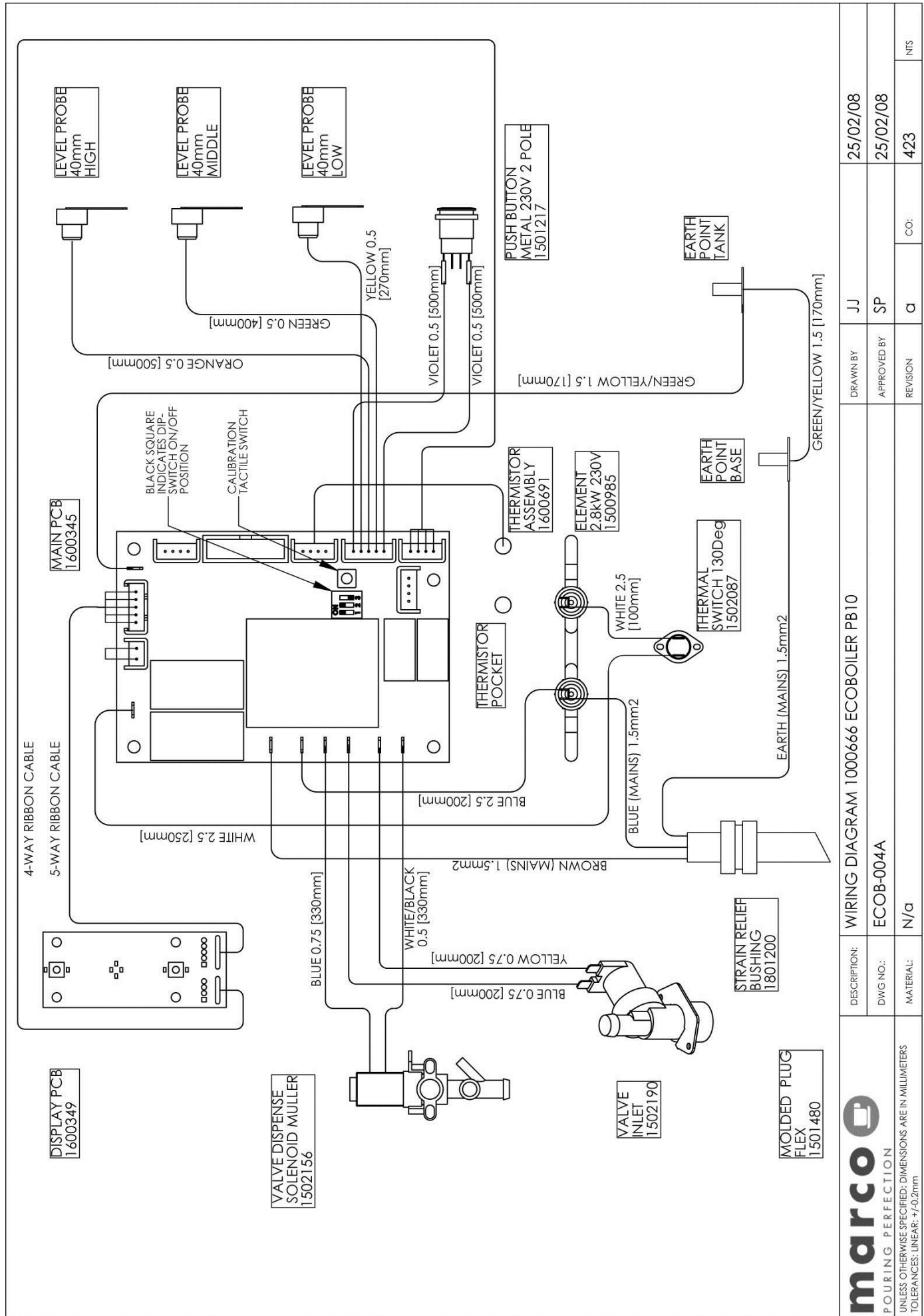

<p>marco POURING PERFECTION UNLESS OTHERWISE SPECIFIED: DIMENSIONS ARE IN MILLIMETERS TOLERANCES: LINEAR: +/0.2mm</p>	DESCRIPTION:	WIRING DIAGRAM 1000666 ECOBOILER PB10		
	DWG NO.:	ECOBI-004A		
	MATERIAL:	N/a		
	DRAWN BY:	JJ	25/02/08	
	APPROVED BY:	SP	25/02/08	
	REVISION	α	CO:	423
				NTS

4.13. Spare Parts List

Part Number	Description	Model Variant			
		T5	T10	PB5	PB10
1400550	Circlip for Tap	X	X		
1401170	Nut Chromed for Tap	X	X		
1500985	Element 2.8kW 230V	X	X	X	X
1501217	Push Button Metal 230V			X	X
1501430	Moulded Plug and cord	X	X	X	X
1502156	Valve Dispense Solenoid Muller			X	X
1502190	Valve Inlet Solenoid	X	X	X	X
1600345	PCB Ecoboiler Control Rev 2.0	X	X	X	X
1600348	PCB Ecoboiler Display 5L Rev 1.0	X		X	
1600349	PCB Ecoboiler Display 10L Rev 1.0		X		X
1600691	Thermistor Assembly	X	X	X	X
1800306	Gasket Inner – Ecoboiler	X	X	X	X
1800307	Gasket Outer – Ecoboiler	X	X	X	X
1801425	Facia Front S/S Top Ecoboiler 5L	X		X	
1801426	Facia Front S/S Top Ecoboiler 10L		X		X
1801427	Facia Plastic Middle Ecoboiler	X	X	X	X
1801428	Facia Front S/S Bottom Ecoboiler	X	X	X	X
1900397	Label Round P&H Hot Water			X	X
1900651	Label Facia 5L – Ecoboiler	X		X	
1900652	Label Facia 10L – Ecoboiler		X		X
2100279	Tap Hot Water	X	X		
2300271	Drip Tray Complete - Ecoboiler	X	X	X	X
2200704	Surround 5L Ecoboiler	X		X	
2200706	Surround 10L Ecoboiler		X		X
2300384	Lid Inner Ecoboiler Complete	X	X	X	X
2300386	Lid Outer Ecoboiler Complete	X	X	X	X
2301463	Level Probe Assembly	X	X	X	X
8000240	Urn Cleanser (800g Tub)	X	X	X	X
8800121	Descaler Box – 6 Packs	X	X	X	X

